

DVH 600



The DVH 600 was developed particularly for use in footpaths/cycleways, verges and parking lots.

DVH rollers have set standards not only with regard to design, but also in performance, longevity, operational safety and environmental protection.

- Front-mounted engine for easy maintenance
- Large-volume water tank
- Guide bar with stepless speed adjustment and dead man's control
- Vibration can be switched on and off via hand lever at any engine speed
- Less vibration transmission to the handle thanks to isolated engine assembly
- Fast gear facilitates movements on construction site
- Central lifting device for easy, safe transport
- Mechanical parking brake to prevent unintended movements

The DVH 600 and its technical data.

Model		DVH 600
machine weight	kgs (lbs)	400 (880)
operating weight	kgs (lbs)	420 (925)
drum width	cms (in.)	65 (25,6)
drum diameter	cms (in.)	32,5 (13)
centrifugal force	kN (lbs)	10 (2250)
frequency	Hz (rpm)	60 (3600)
engine make		Lombardini
engine type		Diesel 15 LD 315
max. output, DIN 70020	kW/HP	5.0/6.8

We reserve the right to alter these specifications

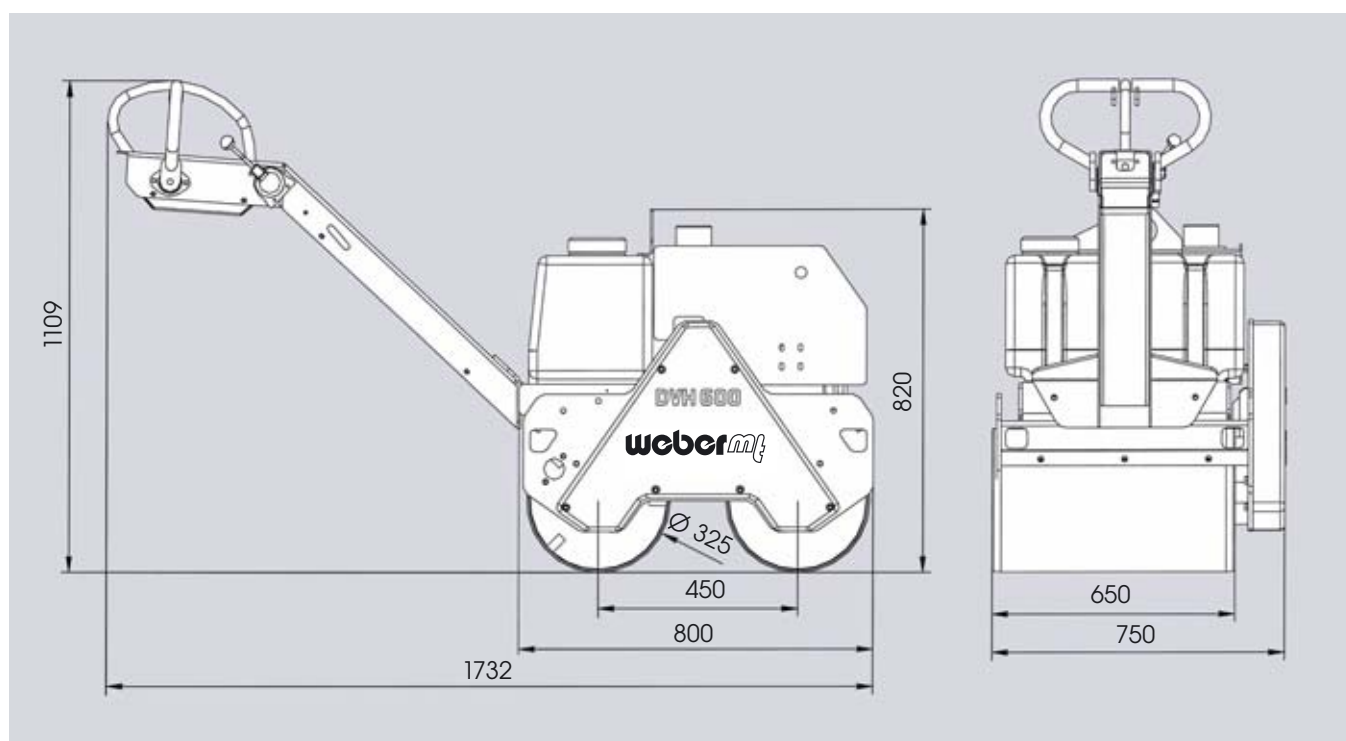

Dimensions in mm